

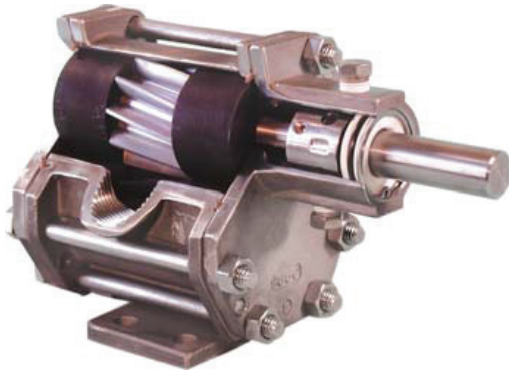

**OBERDORFER**<sup>®</sup>

An Ingersoll Rand Business

## S210 METALLIC CHEMSTEEL SERIES



A full range of accessories are available including:

- line mounted pressure relief valves
- pump mounting foot for use with footless motors
- pedestal assembly

### General Description

Chemsteel pumps are designed to handle common and highly corrosive liquids that must be pumped under pressure. Manufactured to extremely precise tolerance, the Chemsteel pump line prevents system contamination while maintaining the purity and integrity of the liquid being pumped. Its rugged, three-section, o-ring sealed thru-bolt construction provides ease of servicing and parts replacement.

Helical gearing offers noise reduction by as much as 10db, while the tandem pumps double the output flow for a single fluid, or with isolation, handle other fluids in direct ratio to the first.

Additionally, Chemsteel pumps offer bi-directional operation for applications requiring reversing flow.

MODEL	S210	
MAXIMUM FLOW (GPM/LPM) @1750 RPM	5.6 GPM	21.2 LPM (1.3 m <sup>3</sup> /h)
THEORETICAL DISPLACEMENT	14.9 CC/REVOLUTION	
MAXIMUM DIFFERENTIAL PRESSURE	150 PSIG	10.3 BAR
MAXIMUM SYSTEM PRESSURE	300 PSIG	20.7 BAR
MAXIMUM SPEED	1800 RPM	
MAXIMUM FLUID TEMPERATURE	450° F	232° C
MINIMUM FLUID TEMPERATURE	-50° F	-46° C
NPSHR @ 1750	4 FEET	1.2 M
STANDARD PORT SIZE	1/2" FNPT	1/2" BSPT
WEIGHT-LESS MOTOR	6 LBS	2.7 KG

### Performance

Capacity water at 70° F / 21.2° C

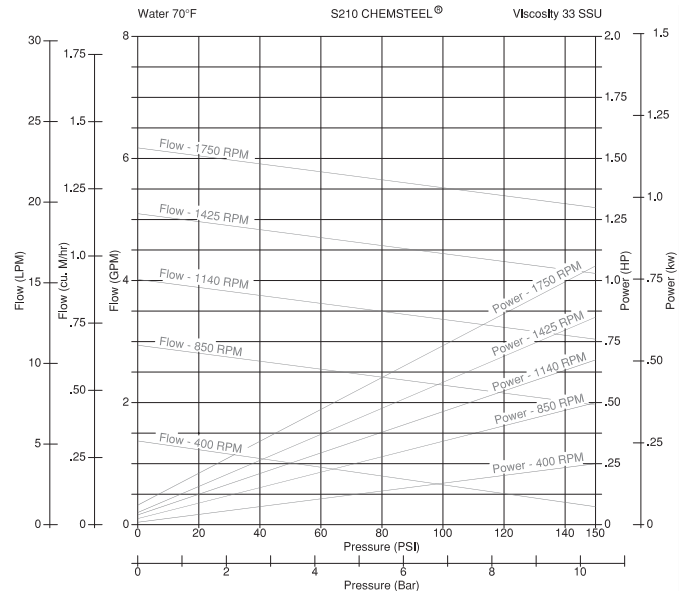

Notes: For continuous service:

- Plastic / Plastic gear combinations are limited to 50 psi or 3.5 bar.
- Metal / Plastic gear combinations are limited to 100 psi or 7 bar.
- Metal/Plastic gear combinations are limited to 150 psi or 10.3 bar.
- Horsepower requirements increase for viscous fluids.

### Specific Solutions

Gear/bearing design allows for “trimming” for optimizing the pump’s maximum flow to reach minimum turndown or to match flow to a specific OEM’s requirement.

Special materials combinations are available for specific liquids:

- 316 stainless or Alloy C housing construction.
- Gears available in 316 stainless, W88 stainless and Alloy C. Also in Teflon<sup>®</sup>, Ryton<sup>®</sup> and PEEK<sup>®</sup>.
- Shafts are 316 stainless steel or Alloy C.
- Bearings available in Carbon, or PTFE.
- Full range of seal options including lip seal and mechanical design.

### Life Cycle/Cost of Ownership

Pump design and materials selection, together provide the longest life available from a gear pump. Key attributes include:

- Gear & bearing combinations of metallic and nonmetallic wear surfaces.
- Slotted bearings to lubricate shaft and gear surfaces.
- Hydraulic porting to balance axial thrust and to reduce wear.
- Ample port sizing to reduce the likelihood of cavitation when inlet pressure is marginal.
- Effective housing seals with elastic memory prevent leakage of corrosives.



**OBERDORFER**<sup>®</sup>

An Ingersoll Rand Business

## Maintenance

A three-part housing provides easy disassembly and service. Full size bearings match the gear diameter, and eliminate the need for separate wear plates. TFE encapsulating silicone o-ring pump housing seals provide elastic memory to assure an effective long lasting seal and thus avoiding the re-torquing required of pumps using pure TFE.

To order a CHEMkit<sup>®</sup>, simply add a "K" to the end of the model number. A repair kit contains the following parts: bearings, gears, o-rings, shafts, keys, c clips, and retaining ring.

## Fit

Connections are 1/2" female NPT or BSPT, pump hardware is metric and close couple adapters mount to both NEMA and IEC standard motor frame sizes for world wide acceptance. "Near" dimensional interchangeability offers easy upgrade to Chemsteel pump. The port size is the same as competitive pumps.

## Dimensions

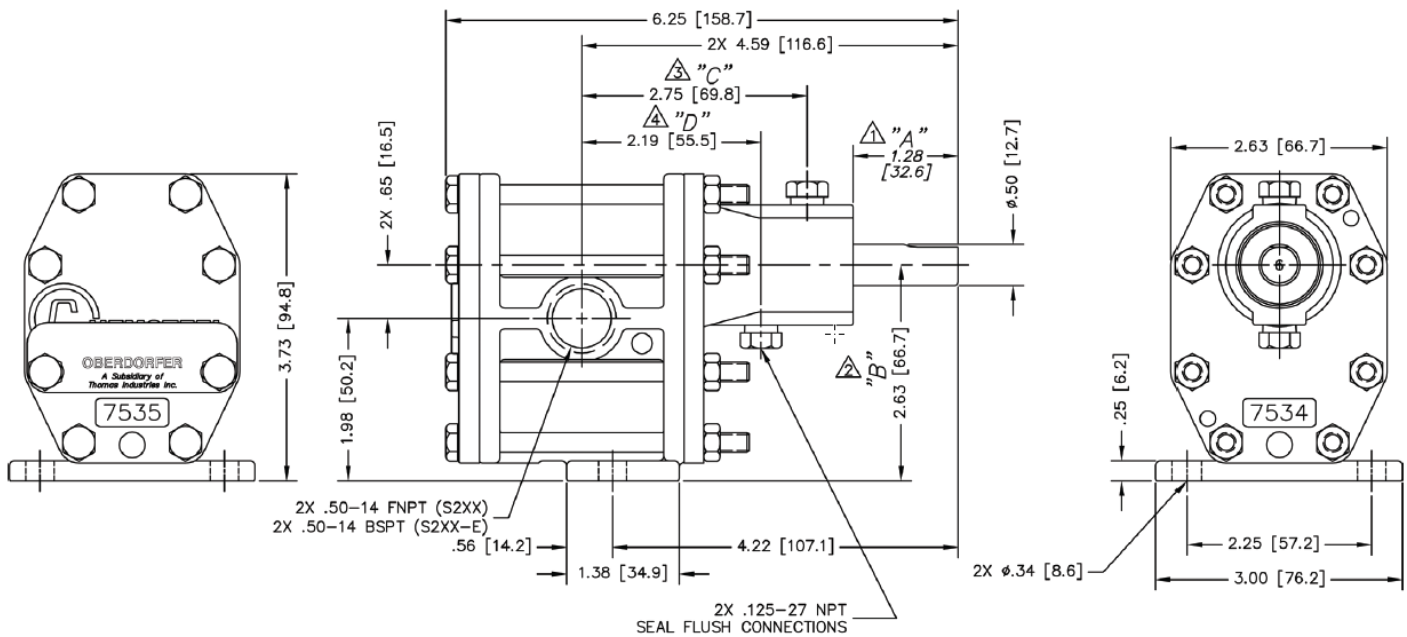

1. Dimension A is approximately .72 [18.2].  
Dimension A is 1.26 [32.0] for lip seal pumps.
2. Standard upper drive shown.  
For lower drive arrangement dimension B is 1.33 [33.7]
3. Dimension C is approximately 2.25 [57.2] for packing pumps with lantern lube port option  
Dimension C is 2.05 [52.1] for lip seal pumps.
4. Dimension D is N/A for packing pumps.  
Dimension D is 2.05 [52.1] for lip seal pumps.



12500 South Pulaski Road  
Alsip, IL 60803, USA  
Phone (800) 448.1668



**OBERDORFER**<sup>®</sup>

An Ingersoll Rand Business

CLOSE-COUPLED DIMENSIONS: C3 & C4 (C3 SHOWN)

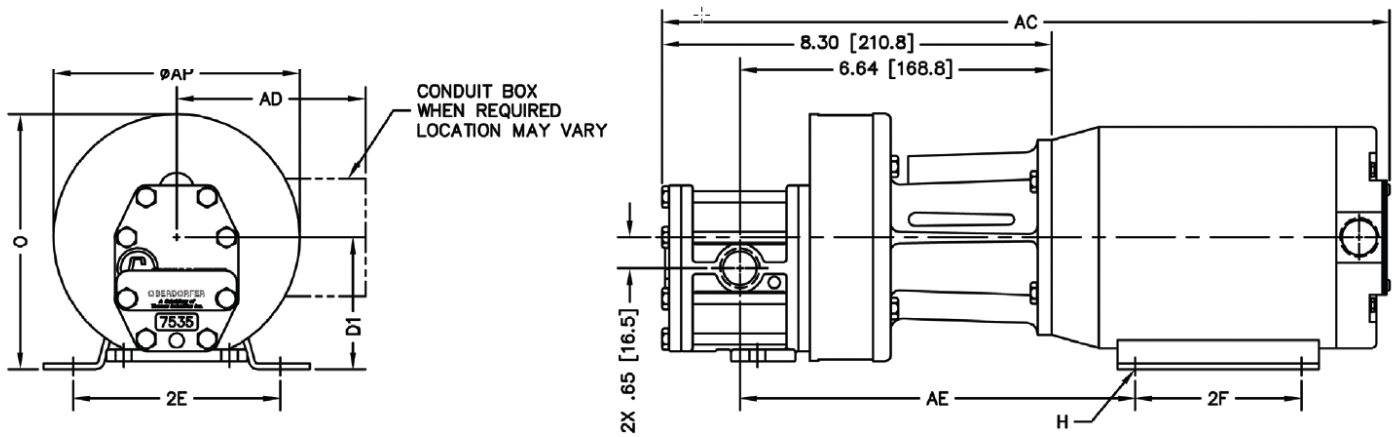

MOUNTED ADAPTER CODE	KIT PART NO.	MOTOR FRAME		D1	2E	2F	H	O	AP	AC	AD	AE
C3	OBM2AD71E	IEC 71, B14 FACE	INCHES	2.80	4.41	3.54	.28 SLOT	5.14	4.69	17.61	4.00	8.42
			MILIMETERS	71	112	89.9	7 SLOT	130.6	119.1	447.3	102	213.9
C4	OBM2AD80E	IEC 80, B14 FACE	INCHES	3.15	4.92	3.94	.39 SLOT	6.00	5.69	17.84	4.51	8.62
			MILIMETERS	80	125	100.1	10 SLOT	152.4	144.5	453.1	116	218.9

CLOSE-COUPLED DIMENSIONS: C1 & C2 (C1 SHOWN)

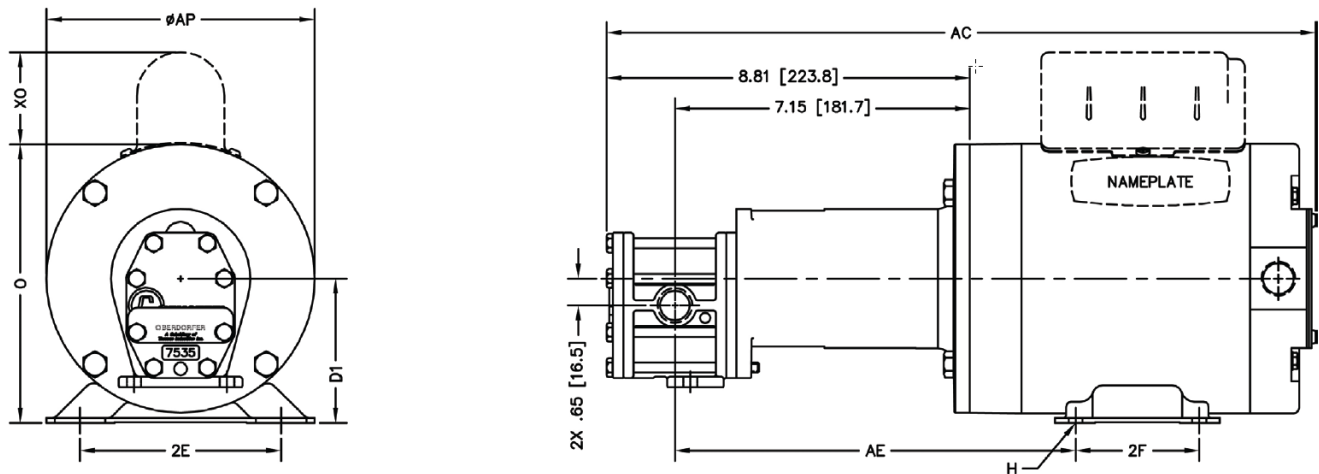

MOUNTED ADAPTER CODE	KIT PART NO.	MOTOR FRAME		D1	2E	2F	H	O	AP	XO	AC	AE			
C1	OBM2AD56	56C	INCHES	3.50	4.88	3.00	.34 SLOT	6.88	6.63	2.25	17.18	9.71			
			MILIMETERS	88.9	124	76.2	8.6 SLOT	174.8	168.4	57.2	436.4	246.6			
C2	OBM2AD54T	143TC	145TC	INCHES	3.50	5.50	4.00	5.00	.34 SLOT	6.88	6.63	2.25	18.37	19.87	9.53
				MILIMETERS	88.9	139.7	102	127	8.6 SLOT	174.8	168.4	57.2	466.6	504.7	242.1
C2	OBM2AD54T	182C	184C	INCHES	4.50	7.50	4.50	5.50	.41 SLOT	8.69	7.88	2.38	21.09	20.31	10.03
				MILIMETERS	114.3	190.5	114.3	139.7	10.41 SLOT	220.7	200	60.3	535.7	515.9	254.8



12500 South Pulaski Road  
Alsip, IL 60803, USA  
Phone (800) 448.1668